

**FITTING INSTRUCTIONS**

**TOOLS**

- 16mm Socket
- 18mm Socket
- 15mm Ring Spanner

**INSTALLATION**

1. Remove existing towhook from RH side. Retain the 2 nuts and discard the tow hook & bolt.
2. Remove patent fastener (speednut) from inner hole (ref.4 Diag.2).
3. Insert nut plate supplied up into crossmember with plate facing forward as shown (ref.Diag.2)
4. Lift RH top bracket up into place over studs & refit 2 nuts from towhook, then fit M10x30 bolt with flat washer & spring washer up into nut plate & tighten (torque 44Nm)(ref.Diag

Diag.1

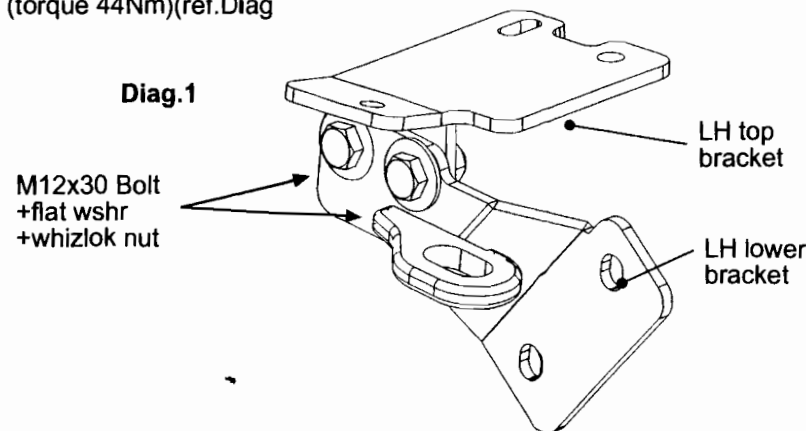

5. On LH side, insert nut plate into crossmember as per step 3.
6. Insert u-bolt supplied through 2 holes in crossmember as shown (ref7Diag.2)

7. Lift LH top bracket up into place over u-bolt & fit 2 x M10 whizlok nuts, & fit M10x30 bolt with spring washer & flat washer up into nut plate & tighten (torque 44Nm).
8. Fit LH & RH lower brackets to top brackets using M12x30 bolts with flat washers, & whizlok nuts, & leave loose.
9. Lift grille guard up into place & fasten with M12x25 bolts with spring washers & flat washers, & leave loose.
10. Tighten M12x30 bolts fitted in step 8 (torque 77Nm).
11. Check grille guard is level & tighten M12x25 bolts (torque 77Nm).

